

SentryHound-Pro Ferromagnetic Portal
User Manual (covers fixed and folding models) Version 1.8



Table Contents

Introduction.....	2
Unpacking Unit.....	3
Powering Up Unit.....	4
Unfolding Sensor Poles.....	4
Controls and Alerts	5
Beacon Alert Colors.....	6
Controlling SentryHound-Pro.....	8
More About Ferrous Detection.....	9
Operational Modes.....	10
Free Standing Gated Tethered Portal.....	10
Free Standing Gated Untethered Portal.....	11
Wall Mounted Unidirectional.....	12
Free Standing Unidirectional.....	13
Free Standing Omnidirectional.....	14
Free Standing Bidirectional	15
Sensitivity Settings.....	16
Alert Settings.....	17
Battery Levels.....	18
Dry Contact Trigger Diagram.....	19
SentryHound-Pro Mechanical Drawings.....	20

Introduction

This user manual covers both original SentryHound-Pro (non-folding sensor poles) and newer SentryHound-Pro folding ferrous detection portal. Both models operate in the same way with the same UI and button layout on the base. The sensor poles look different between the two models and the folding model requires unfolding in order to operate but otherwise, they are the same aside from minor differences that will be detailed in this user manual when relevant.

SentryHound-Pro™ Ferromagnetic Contraband Portal is a dual or single pole solution to detect unauthorized or illegal PEDs (Personal Electronic Devices) including cell phones, tablets, laptops, smartwatches, wearables and even weapons including guns and knives. SentryHound-Pro's ferromagnetic inspection zones are highly sensitive to trace amounts of ferrous material found in plastic cell phones and miniaturized electronics. These same devices slip through regular metal detectors without detection but not SentryHound-Pro because of its sensitivity, unique motion detection and enhanced false trigger rejection. This allows for a rapid security checkpoint of pockets, bags, purses, clothing and even body cavities.

- Ferromagnetic Contraband Portal (2 poles included) for the quickest & most accurate ferromagnetic inspection security checkpoint
- Single pole setup anywhere in under 30 seconds
- Lightweight, versatile & all day battery power
- Sealed against the elements for rugged indoor/outdoor use
- 2nd pole easily untethered to use for additional security checkpoint
- Vastly reduced false detection compared to standard metal detectors
- Full ferromagnetic security checkpoint zone up to 64" wide by 75" high
- Detects contraband cell phones (ON or OFF), smartwatches, wearables, tablets, portable electronics, weapons
- Key lockable for security reassurance
- Most advanced ferromagnetic contraband portal available with distinct ferromagnetic inspection zones to pinpoint contraband
- Advanced motion detection and false trigger rejection using dual pole configuration
- Perfect for FBoP, DoD, NSA, FBI & any secure government or military SCIF
- Designed and manufactured entirely in the U.S.A.

Unpacking Your Unit

SentryHound-Pro ships in a protective carton designed specifically for the hardware. Be sure to keep this box and all packing materials in case unit needs to be sent back to factory for repairs or updates. Once you have unpacked all items and have made yourself accustomed with SentryHound-Pro features, typical setup for the unit can be accomplished in only 30 seconds.



(non-folding SentryHound-Pro) Shipping box dimensions (1 pole per box) 70" x 13" x 7" (178cm x 33cm x 18cm) and 25 lbs. (11kg) with accessories



Complete portal systems require (2) of these packages.



(folding SentryHound-Pro) Pelican 1720 case dimensions (1 pole per case) 45" x 17" x 57" (114cm x 43cm x 18cm) and 37 lbs. (17kg) total with accessories. Some customers prefer these optional Pelican cases to store and transport sensor poles.

Powering Up Unit

Be sure to keep the unit charging using the included charger in case you need to move it into an area where there are no nearby power outlets. It can take several hours to fully charge. When you first power the unit on, it will automatically enter into a calibration procedure taking approximately 30 seconds to complete. SentryHound-Pro self-calibrates so you do not need to calibrate manually unless the unit is moved to a different location. After the unit has been moved, you should always press the CALIBRATE button and wait 30 seconds. While the unit calibrates, do not stand within 5 feet of it and make sure there is no movement of large ferrous objects in the area. If calibration is interfered with in any way, you can simply press the CALIBRATE button again.

Unfolding Sensor Poles

For folding SentryHound-Pro sensor poles, users must first unfold poles by loosening knobs, straightening the poles and re-tightening the knobs to securely lock the poles into place. Once sensor poles are straightened, users can power up, calibrate and operate the unit as normal.

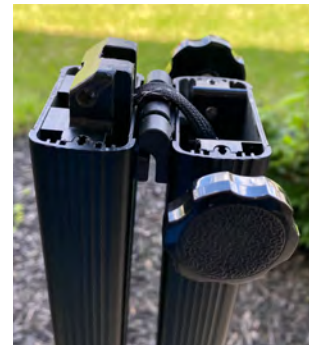
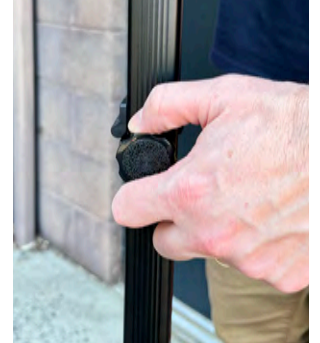

Controls and Alerts

SentryHound-Pro is housed in a rugged aluminum chassis with weather resistant seals and buttons. The internal 12V sealed lead acid battery takes approximately 3 hours to fully charge and lasts approximately 24 hours under normal operation. The unit includes 5 color-coded buttons, a physical lock and key, dry trigger contact and USB port on the top of the base.

The front side (product name etched in this side) of the base includes a motion sensor that only triggers the alarms if ferrous material is detected while someone is moving past this sensor. On the bottom left of the front side of the base is the power input connector for charging the internal battery.

The rear side of the base includes a motion sensor just like on the other side of the base and also an infrared sensor for communication between two pole configurations. This is useful for setting up various configurations detailed later in this user manual.

Then pole contains (4) alert zones that detect ferrous material all the way from the floor up to over the top of the alert dome on the top of the pole. This ensures that the tallest subjects passing through the poles cannot hide contraband in their shoes or any kind of headwear. Each zone blinks to indicate the approximate area where the ferrous material is detected. The dome light on top of the pole blinks for alerts but also to indicate the unit is ready for the next ferrous scan. All LEDs on the pole can change color to indicate the current mode or setup or operation.

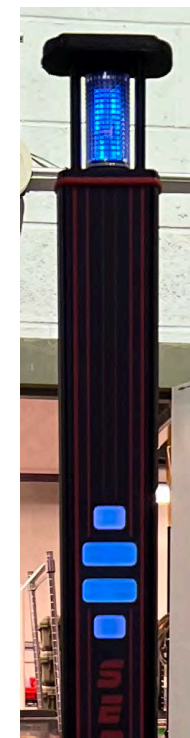

Beacon Alert Colors

The light atop the sensor pole can indicate modes independently of other visual alerts and sounds. Make note of the beacon's color and/or blinking to understand the corresponding modes. Both folding and non-folding SentryHound-Pro models operate and use the same alerts.



Solid green indicates that the unit is ready for detection. Always wait for solid green before letting anyone pass by the unit.



Blinking red (adjustable duration using ALERT button) indicates positive detection of ferrous material. Red LED alert zone clusters in sensor pole stay solid to indicate area of ferrous detection.



Solid yellow indicates calibration in progress. Allow the unit to fully calibrate (about 30 seconds) without any nearby (about 5 feet away) ferrous movement. Once the beacon turns green, allow foot traffic to resume for detection.



Blinking blue (same duration as positive detection) indicates that subject needs to be screened again. This indicates detection of high background noise during the first pass. Once beacon light goes back solid green, subject must pass by unit again to properly check for ferrous material.

Controlling SentryHound-Pro

SentryHound-Pro buttons are color-coded to match the color of the LED alerts and configuration modes in the pole. Some of these buttons require holding down in combinations to enter into different detection configurations. Consult this manual fully or the included quick start guide for more details.



ON/OFF Button – Push this button to power on SentryHound-Pro. Hold button in for 3 seconds to power the unit back off.



BATTERY LEVEL – Push this button to check the level of the internal battery. The alert zones on the pole light up to from the bottom to the top to indicate 25%, 50%, 75% or 100% capacity.



CALIBRATION – Push this button to calibrate the unit at any time. The process takes about 30 seconds. You should also push this button if the unit is moved to a different location while still powered on.



SENSITIVITY – Push this button adjust detection sensitivity. The higher the sensitivity setting (more LEDs lit on the pole) the more the unit is prone to false triggers.



ALERT – Push this button to cycle through various alert audio and visual durations.



KEY – Turn and remove this key to lock or unlock the unit to prevent tampering. When in the locked position, all settings are static (including main power) and cannot be changed until key is inserted and turned back to the unlock position.



DRY TRIGGER CONTACT – Connect this contact to an external speaker, camera, DVR or visual alert to add additional functionality each time the unit is triggered by ferrous detection.



USB – This port allows the unit firmware to be updated. Be sure to consult with support@bvsystems.com for upgrade steps before performing any update to your unit.



MOTION SENSOR / INFRARED SENSOR – Be sure that unit bases (single or dual pole configurations) are free from obstructions so that these sensors can detect motion and communicate between bases during setup procedures.



POWER INPUT – Use only the provided AC adapter to power and charge the unit here.

MORE ABOUT FERROUS DETECTION

Ferrous detectors are used to detect changes in the earth's omnipresent magnetic field in a space. The detector is initially conditioned to the earth's magnetic field and its immediate surroundings. Many variables can change the magnetic field measured by a ferrous detector such as the introduction of ferrous material around the detector or physical movement of the ferrous detector itself.

Ferrous materials are materials that can be magnetized and also known as ferromagnetic material. They are mostly iron, but can also be nickel, cobalt and some alloys of rare-earth metals, or common magnets. Some common non-ferrous metals are copper and aluminum. Depending upon the composition and purity of material, brass and stainless steel might have some trace of ferromagnetic material in them even if they do not appear to be magnetizable.

Introduction of nearby ferrous material causes perturbation in the earth's magnetic field, and that change is picked up by the ferrous detector. Digital signal processing is applied to the detected change and a visual/audio alert is issued. There are four ferromagnetic sensors in each SentryHound-Pro pole, linearly arranged and equidistant apart from each other so that the sensor with the strangest signal will be visually indicated.

Please note that the following items (not exhaustive list) might have enough ferrous material to trigger a ferrous detector: rolling office chairs, large trucks moving outside, metal eyeglass frames, belt buckle, shoes, wristwatches, metal zipper, metal buttons or studs within fabric. Another potential source of interference are power supplies in close proximity to the system. Keep power supplies for any electronics and power supply cables of any electronics away from the system. Awareness of these materials will help isolate contraband vs. false triggers which will accelerate screenings and security checkpoints.

Physical stability of the SentryHound-Pro system is very important for proper operation. As noted above, any movement or vibration of the system during operation might disturb the magnetic field and potentially trigger the detector. SentryHound-Pro should NOT be used on any carpet or flooring that has the slightest give when someone walks nearby. If a system is moved at all, it should stabilize after 5 seconds or so to resume detection. However, in certain instances, the extreme movement of the system could trigger a full calibration procedure (as indicated by yellow beacon light on top of pole), and after about 30 seconds, the system will again be ready for detection. Users can, at any time, initiate this calibration manually by pressing the CALIBRATE button.

Operational Modes

There are six unique modes of operation:

- MODE 1: Free standing gated tethered portal
- MODE 2: Free standing gated untethered portal
- MODE 3: Wall-mounted unidirectional
- MODE 4: Free standing unidirectional
- MODE 5: Free Standing omnidirectional
- MODE 6: Free standing bidirectional

Modes 1 and 4 are the most commonly used so this manual will focus mostly on them but all modes are supported using the dual pole configuration. By default, the single pole SentryHound-Pro ships supporting modes 3 and 5. If you have received the dual pole configuration, the default modes are 1 and 2. Modes 4 and 5 require a button combination to activate.

Mode 1: Free standing gated tethered portal

In this mode, two SentryHound-Pro poles are used as a tethered portal in order to guide foot traffic and increase detection distance up to 64 inches between poles. Be sure that both units are placed on solid, level flooring (preferably concrete or tile) with no give or else they might falsely trigger. Once the poles are linked, even small amounts of ferrous material passing anywhere in between the two poles, from ground level up to 75 inches above the ground, will trigger an alert. Poles will only trigger while someone is moving between them meaning security staff can move freely around the portal without triggering any alert.



Setting up this configuration is simple. Be sure both units are placed a few feet apart (you can adjust final spacing later) and that the IR sensors are facing each other. The alert LEDs on one side of the poles, the buttons and the SentryHound-Pro etching on the base should all be viewable and easily accessible from the outside of the portal allowing only foot traffic within the portal to be detected as they pass through.

Once aligned, pressing the POWER button on both units within 4 seconds of each other will automatically link the two poles. The first unit powered on will automatically become the master pole making the other unit the slave. The master unit ALERT button will blink 3 times to indicate that tethering is successful.

Note: If ferrous material passes through the portal at the same time that someone else moves near the portal, there is a risk of false detection. SentryHound-Pro should always be setup in an area with minimal ferromagnetic activity. This activity can include large moving ferrous objects such as wheeled office chairs, filing cabinet drawers, steel doors and even large trucks in a nearby parking lot.

Mode 2: Free standing gated untethered portal

In this mode, two or more SentryHound-Pro poles can be used as a row of multiple untethered portals in order to guide foot traffic through a virtual gate or wall. In this configuration, units allow for foot traffic on either side of the unit without the need for tethering to each other. Be sure all units are placed on solid, level flooring (preferably concrete or tile) with no give or else they might falsely trigger. Once the units are powered on, even small amounts of ferrous material passing anywhere in between the units, from ground level up to 75 inches above the ground, will trigger an alert. Poles will only trigger while someone is moving between them meaning security staff can move freely around the portal without triggering any alert.



Since this configuration does not require any tethering, units may be powered on at any time and do not need to be facing in any particular direction. Press the POWER button on the first unit and wait a few seconds for the ALERT button to blink. Next, turn on the second unit and wait for that ALERT button to blink. Continue doing this to as many units as you would like to align for a full gated effect.

Note: If ferrous material passes through the portal at the same time that someone else moves near the portal, there is a risk of false detection. SentryHound-Pro should always be setup in an area with minimal ferromagnetic activity. This activity can include large moving ferrous objects such as wheeled office chairs, filing cabinet drawers, steel doors and even large trucks in a nearby parking lot.

Mode 3: Wall-mounted unidirectional

In this mode, one SentryHound-Pro unit is typically mounted to a wall near a doorway or down a narrow hallway using the optional wall mounting kit. Single pole detection range typically falls between 18 and 32 inches so be sure that foot traffic is not too far away from the sensors in the pole. Also be sure that there are no ferrous sources that could be moving on the other side of the wall.

In this configuration, the base of the unit must be removed in order to allow mounting to the included wall bracket. Be sure the unit is mounted on solid wall as low as possible toward the floor, otherwise contraband could be slip by the sensors undetected. Once the units are powered on, even small amounts of ferrous material passing anywhere in between the units, from ground level up to 75 inches above the ground, will trigger an alert. Poles will only trigger while someone is moving between them meaning security staff can move freely around the portal without triggering any alert.

This configuration requires the unit to face away from the wall it is mounted to in order to see the LED alerts and have access to the controls. Press the POWER button and wait a few seconds for the ALERT button to blink.

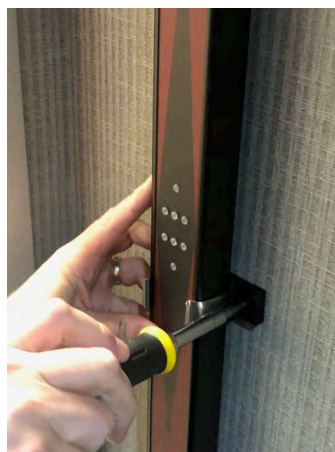
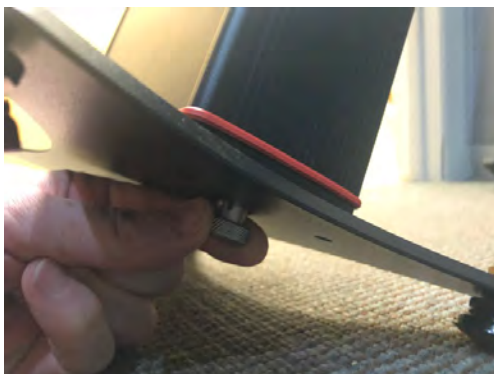

Mode 4: Free standing unidirectional

In this mode, one SentryHound-Pro unit can be used for foot traffic passing by only one side of the unit. Be sure that unit is placed on solid, level flooring (preferably concrete or tile) with no give or else it might falsely trigger. Once powered on, even small amounts of ferrous material passing within 18 to 32 inches from the pole and from ground level up to 75 inches above the ground, will trigger an alert. The unit can only trigger while someone is moving past the sensors meaning security staff can move freely around the portal without triggering any alert.

The alert LEDs on one side of the poles, the buttons and the SentryHound-Pro etching on the base should all be viewable and easily accessible for security personnel while foot traffic should only move on the opposite side of the unit.

Hold the POWER + CALIBRATION + ALERT buttons while powering up to enter this mode. The ALERT button will then blink 5 times to indicate that this mode has been entered. Remember that even after powering off and on again, this mode will still be active unless you return to the factory defaults by holding down POWER + ALERT buttons while powering on unit.

Note: If ferrous material passes by the unit at the same time that someone else moves near the portal, there is a risk of false detection. SentryHound-Pro should always be setup in an area with minimal ferromagnetic activity. This activity can include large moving ferrous objects such as wheeled office chairs, filing cabinet drawers, steel doors and even large trucks in a nearby parking lot.



Mode 5: Free standing omnidirectional

In this mode, one SentryHound-Pro unit can be used for foot traffic passing in any side of the unit for situations such as the middle of a hallway or corridor. Be sure that unit is placed on solid, level flooring (preferably concrete or tile) with no give or else it might falsely trigger. Once powered on, even small amounts of ferrous material passing within 18 to 32 inches from the pole and from ground level up to 75 inches above the ground, will trigger an alert.

Hold the POWER + SENSITIVITY + ALERT buttons while powering up to enter this mode. The ALERT button will then blink 4 times to indicate that this mode has been entered. Remember that even after powering off and on again, this mode will still be active unless you return to the factory defaults by holding down POWER + ALERT buttons while powering on the unit.

Note: If ferrous material passes by the unit at the same time that someone else moves near the portal, there is a risk of false detection. SentryHound-Pro should always be setup in an area with minimal ferromagnetic activity. This activity can include large moving ferrous objects such as wheeled office chairs, filing cabinet drawers, steel doors and even large trucks in a nearby parking lot.



Mode 6: Free standing bidirectional

In this mode, one SentryHound-Pro unit can be used for foot traffic passing in either direction such as the middle of a hallway or corridor. Be sure that unit is placed on solid, level flooring (preferably concrete or tile) with no give or else it might falsely trigger. Once powered on, even small amounts of ferrous material passing within 18 to 32 inches on either side of the pole and from ground level up to 75 inches above the ground, will trigger an alert.

When the unit is powered on, the ALERT button will blink once to indicate this default mode. If it does not behave this way, you can return to the factory defaults by holding down POWER + ALERT buttons while powering on the unit.

Note: If ferrous material passes by the unit at the same time that someone else moves near the portal, there is a risk of false detection. SentryHound-Pro should always be setup in an area with minimal ferromagnetic activity. This activity can include large moving ferrous objects such as wheeled office chairs, filing cabinet drawers, steel doors and even large trucks in a nearby parking lot.



Sensitivity Settings

Since we are surrounded by ferrous material all over the planet, nearby movement of this material can falsely trigger the unit depending upon how much material and how close it is to the unit while someone passes through. Depending upon the placement of the sensor poles in a particular ferrous environment and amount of nearby activity, users may need to adjust sensitivity to suit their needs. **Sensitivity setting 1 (bottom blue LED) is recommended for all users as a starting point but since it contains the highest level of filtering, you might need to change the setting if you find that some ferrous material is able to pass by the unit undetected.** Be sure to thoroughly test a variety of ferrous contraband in various environments to learn the best setting for each environment before you put SentryHound-Pro into service for your security needs.

SentryHound-Pro contains 8 sensitivity settings total. Settings 1 - 4 (blue LEDs) filter out nearby ferrous interference linearly from most to least. Settings 5 – 8 (green LEDs) provide more granularity within the first 4 sensitivity levels. These additional levels 5 - 8 are not linear so you will need to test each one if you cannot find a suitable sensitivity level between 1 and 4.

Sensitivity settings also correspond to the detection range. For instance, a sensitivity setting of 2 might not detect a smartphone passing by 32 inches from the nearest sensor but a sensitivity setting of 4 would stand a better chance of detecting that same smartphone passing by 32 inches from the nearest sensor. Of course, sensitivity setting 4 would also be prone to more nearby interference which could lead to false triggers. Each time you relocate SentryHound-Pro into a new environment, you might have to go through each of the sensitivity settings to find the right balance of affirmative detection compared to false detection.

Push the SENSITIVITY button to see the current setting. After 3 seconds, the sensitivity display will stop but if you push the SENSITIVITY button before that, it will increment each time you push the button.

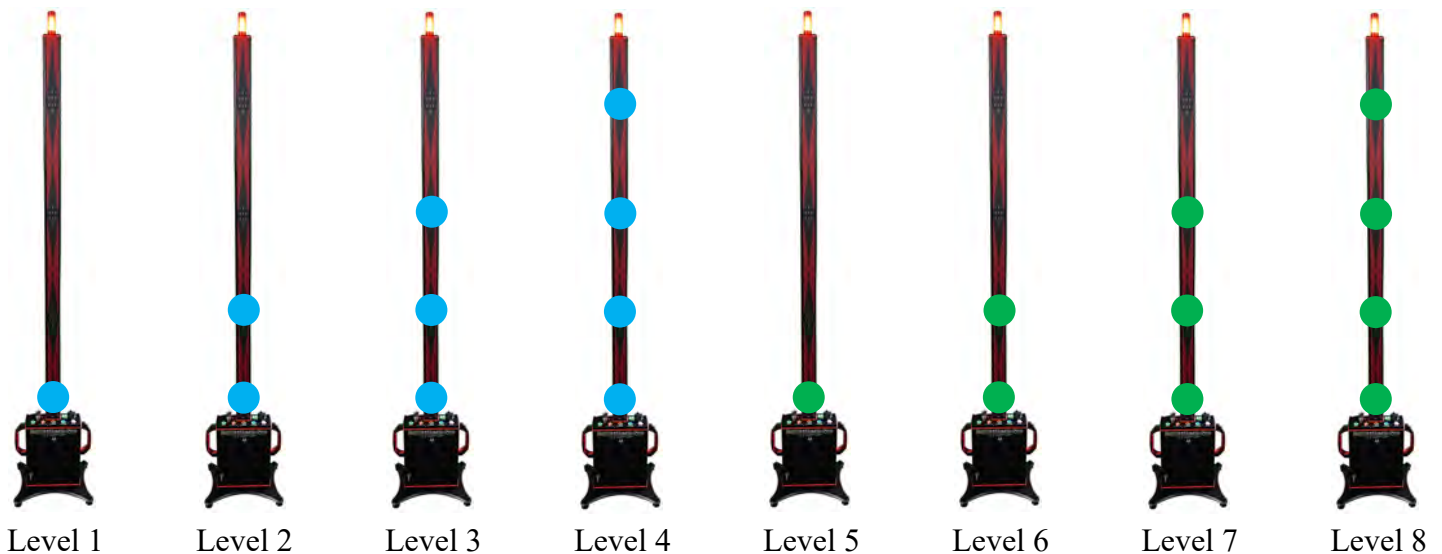

1 - Strong filtering to avoid false positives including large objects passing by such as rolling office chairs and even trucks outside in a nearby parking lot or roadway during regular use.

2 - Medium filtering to avoid false positives such as nearby activity from large ferrous objects moving in the same room as the sensors during regular use.

3 - Medium low filtering for generally cleaner ferrous environments containing less activity nearby.

4 - Low filtering levels for a clean ferrous environment containing little to no activity.

5, 6, 7, 8 - Granular settings beyond first 4 levels for more advanced operation.

Alert Settings

Upon positive detection, SentryHound-Pro emits an audio and visual alert, but these can be customized to fit your needs. The unit contains 8 different alert settings that can be toggled through by pressing the ALERT button. Push the ALERT button to check the current alert settings. After 3 seconds, the alert display will stop but if you push the ALERT button before that, it will increment to the next setting each time you push the button.

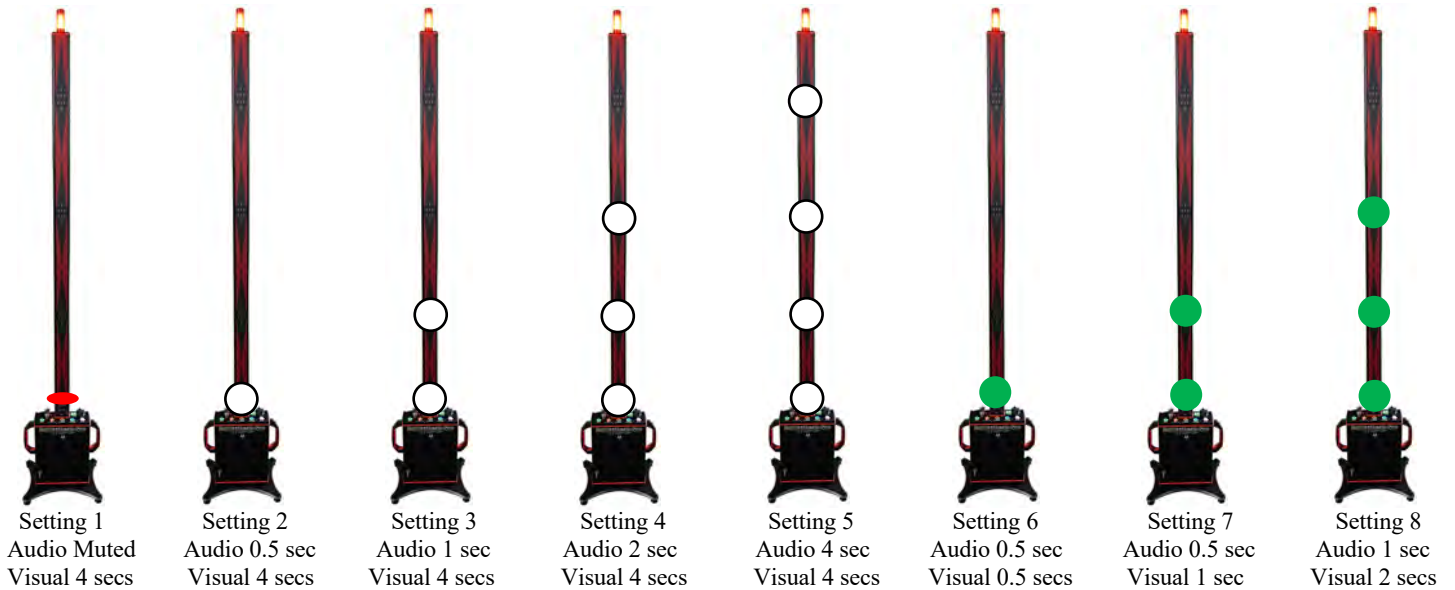

Battery Level

SentryHound-Pro contains an internal, sealed lead acid 12V battery. This battery takes 3-4 hours to charge fully and can operate the unit without any AC power for over 24 hours. Battery power can be checked at any time by pressing the BATTERY button. The LED clusters on the sensor pole will display (for 3 seconds) the remaining battery power in 25% increments. When the lowest cluster is only lit, the battery has about 25% capacity left and when all 4 LED clusters are lit, the battery is 100% charged.



25% Charge



50% Charge



75% Charge



100% Charge

**Three examples of remote alarm triggered from a dry contact in your BVS product
(Similar outputs are provided in all wall-mounted BVS products)**

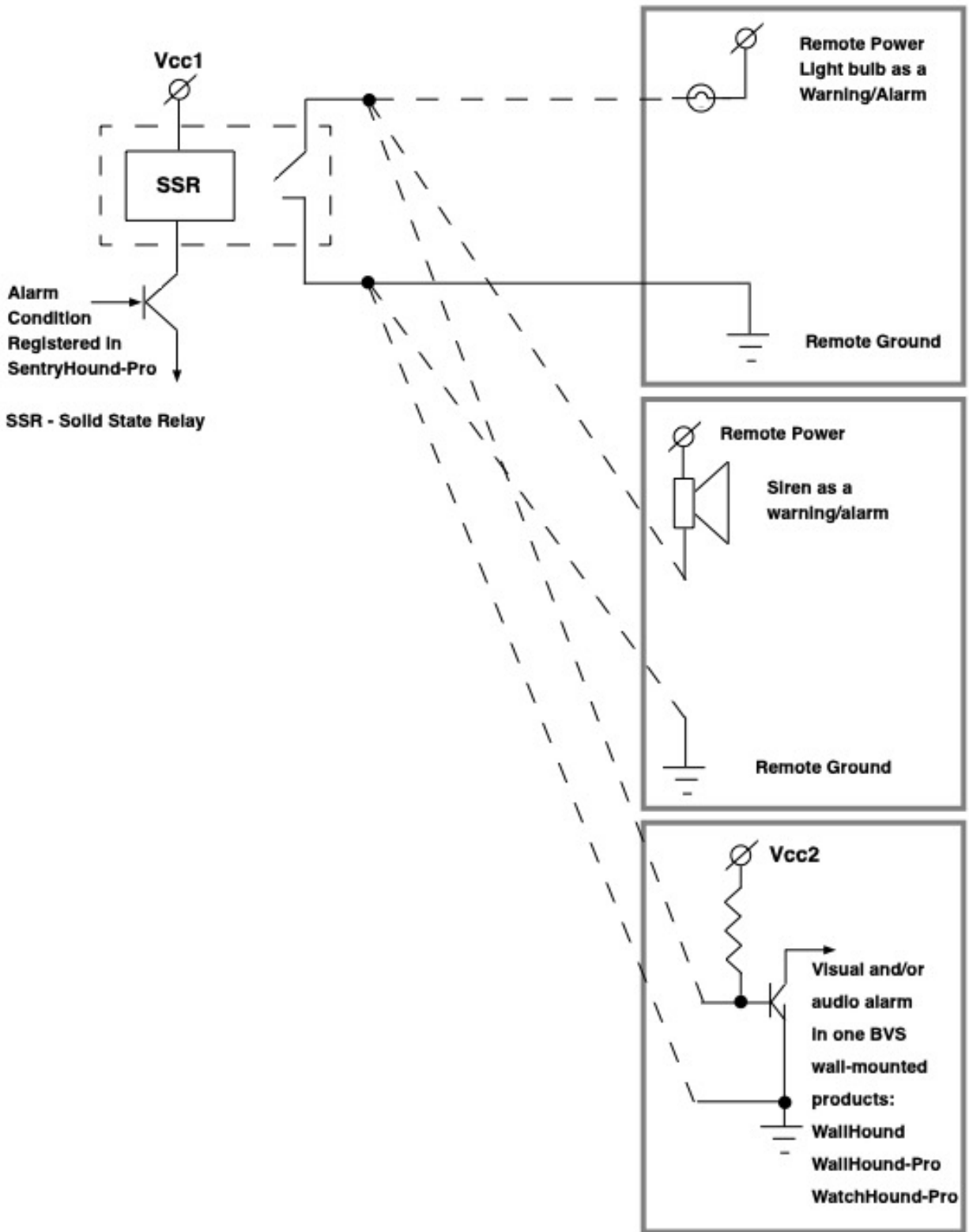

SentryHound-Pro Folding Ferrous Detection Portal

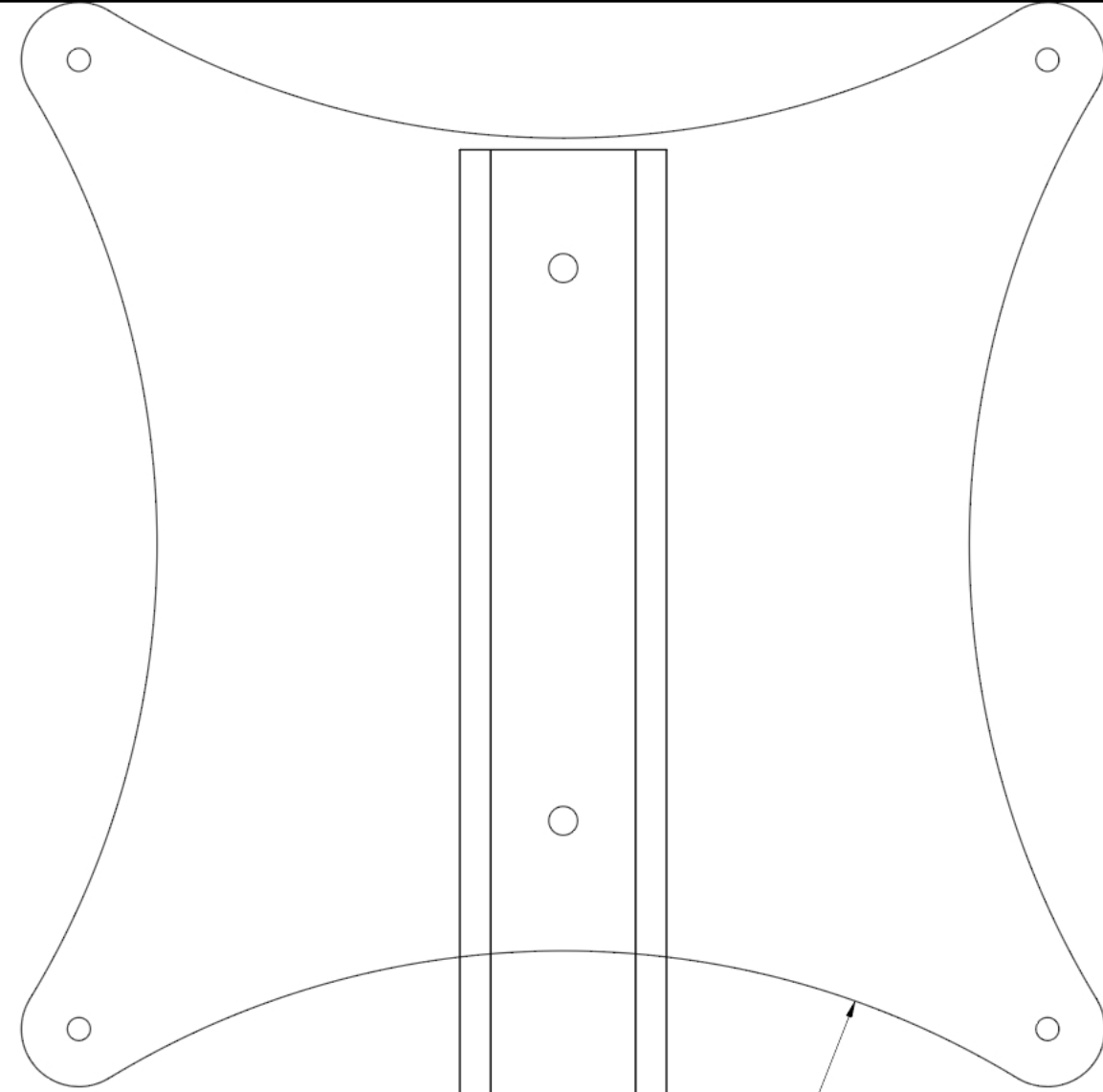

MOUNTING BASE

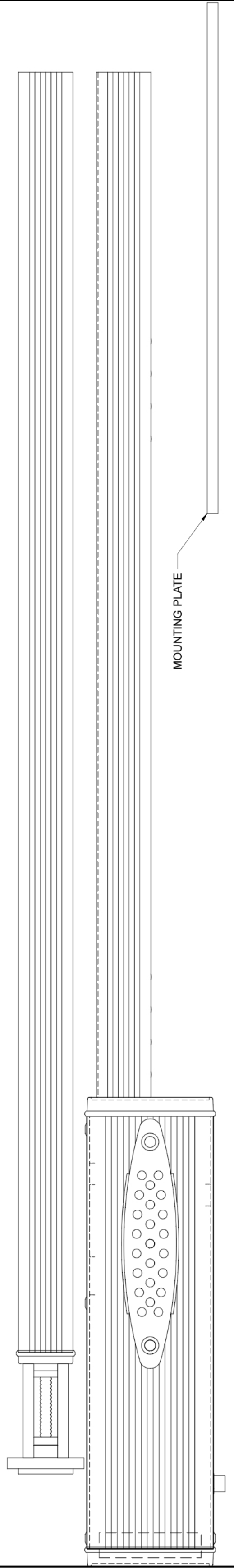
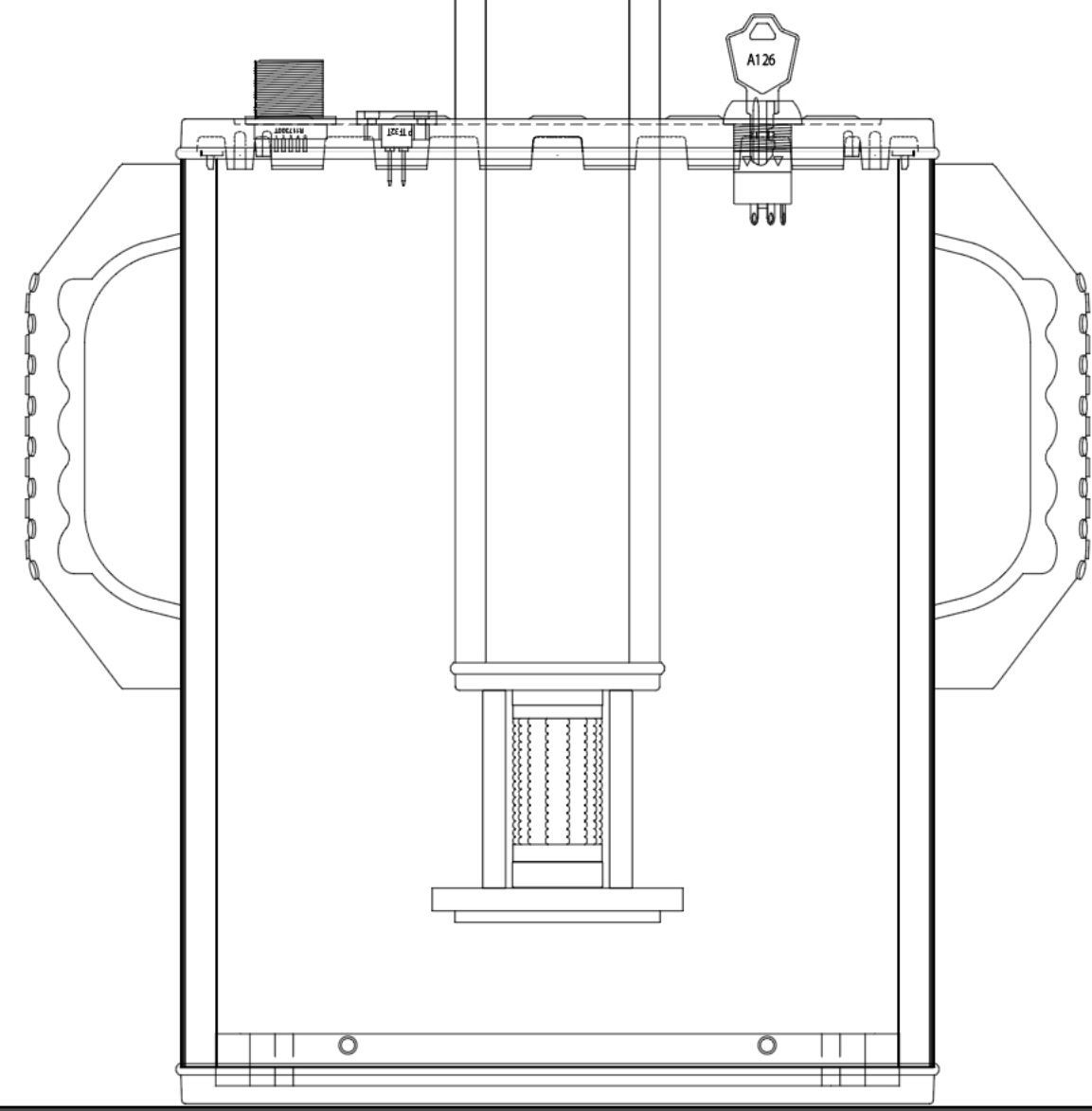

MOUNTING PLATE

SentryHound Pro Standard Base

SENSOR HEIGHTS

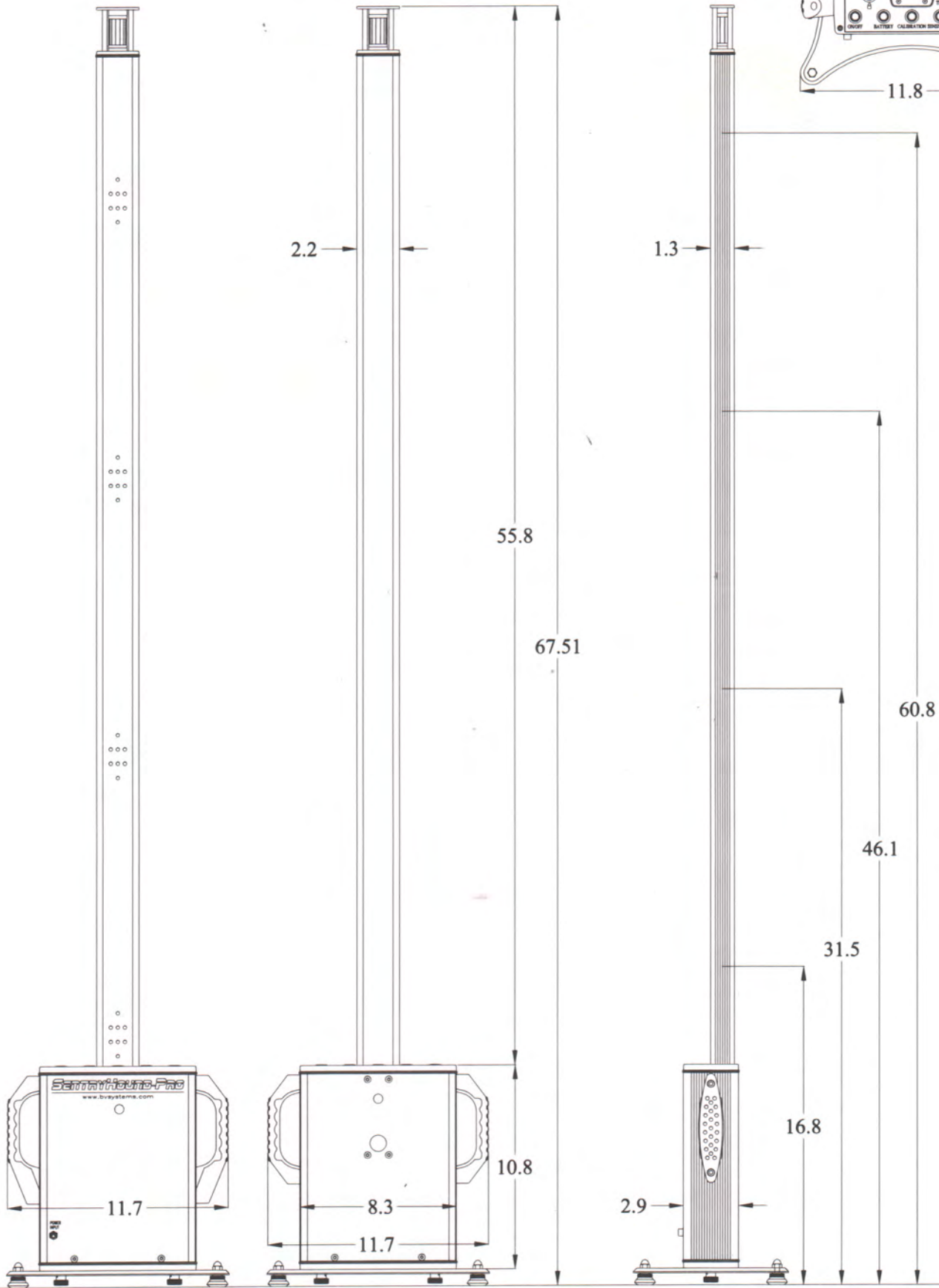
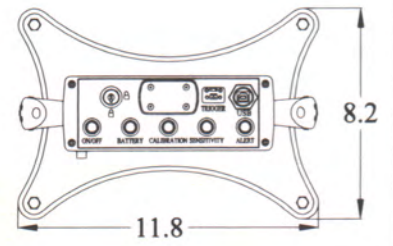

ALL MEASUREMENTS ARE IN INCHES

SentryHound Pro Wall Mount

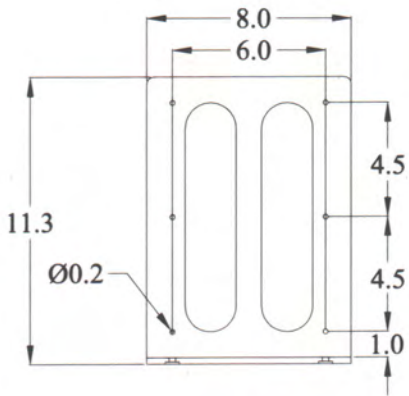
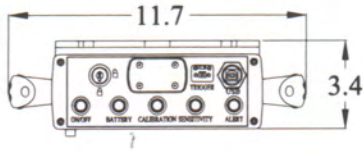

SentryHound Pro
Wall Mount

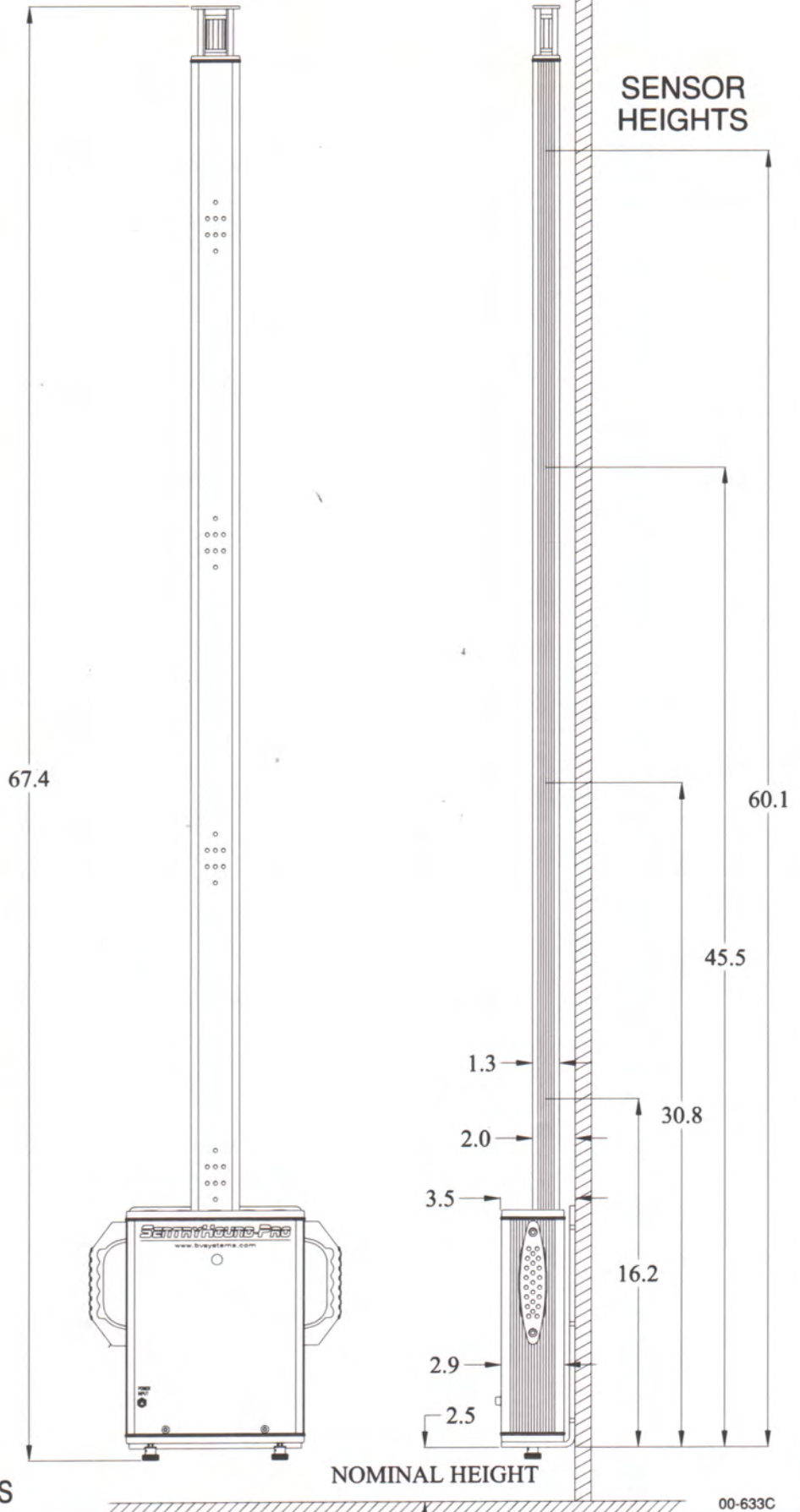

ALL MEASUREMENTS ARE IN INCHES

SentryHound Pro Suction Cup Base

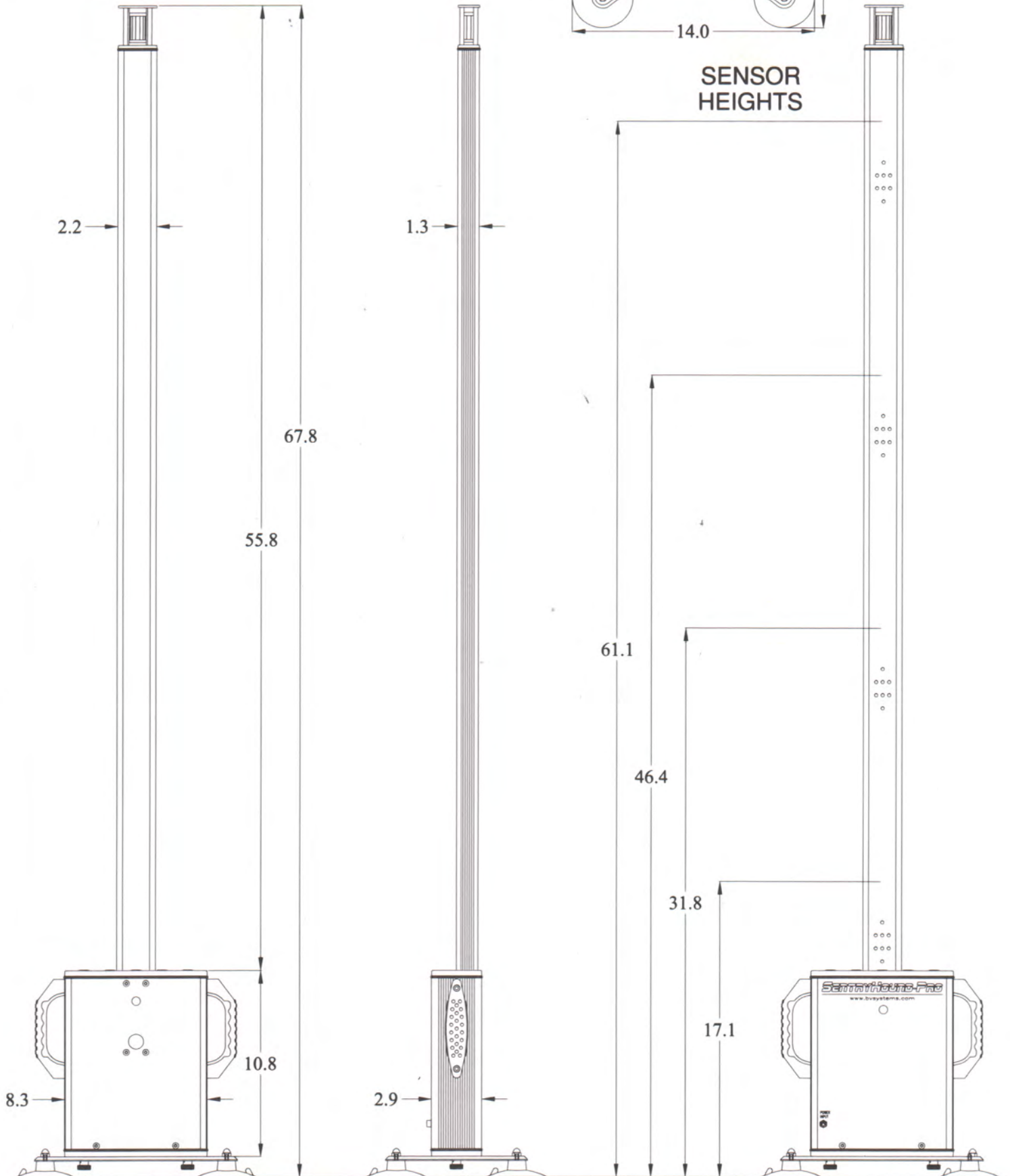
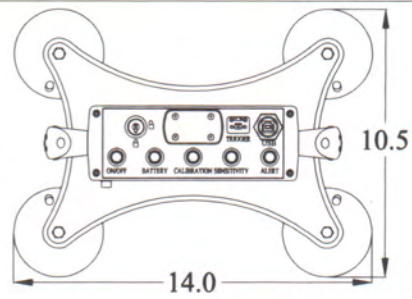

ALL MEASUREMENTS ARE IN INCHES

SentryHound Pro Permanent Base

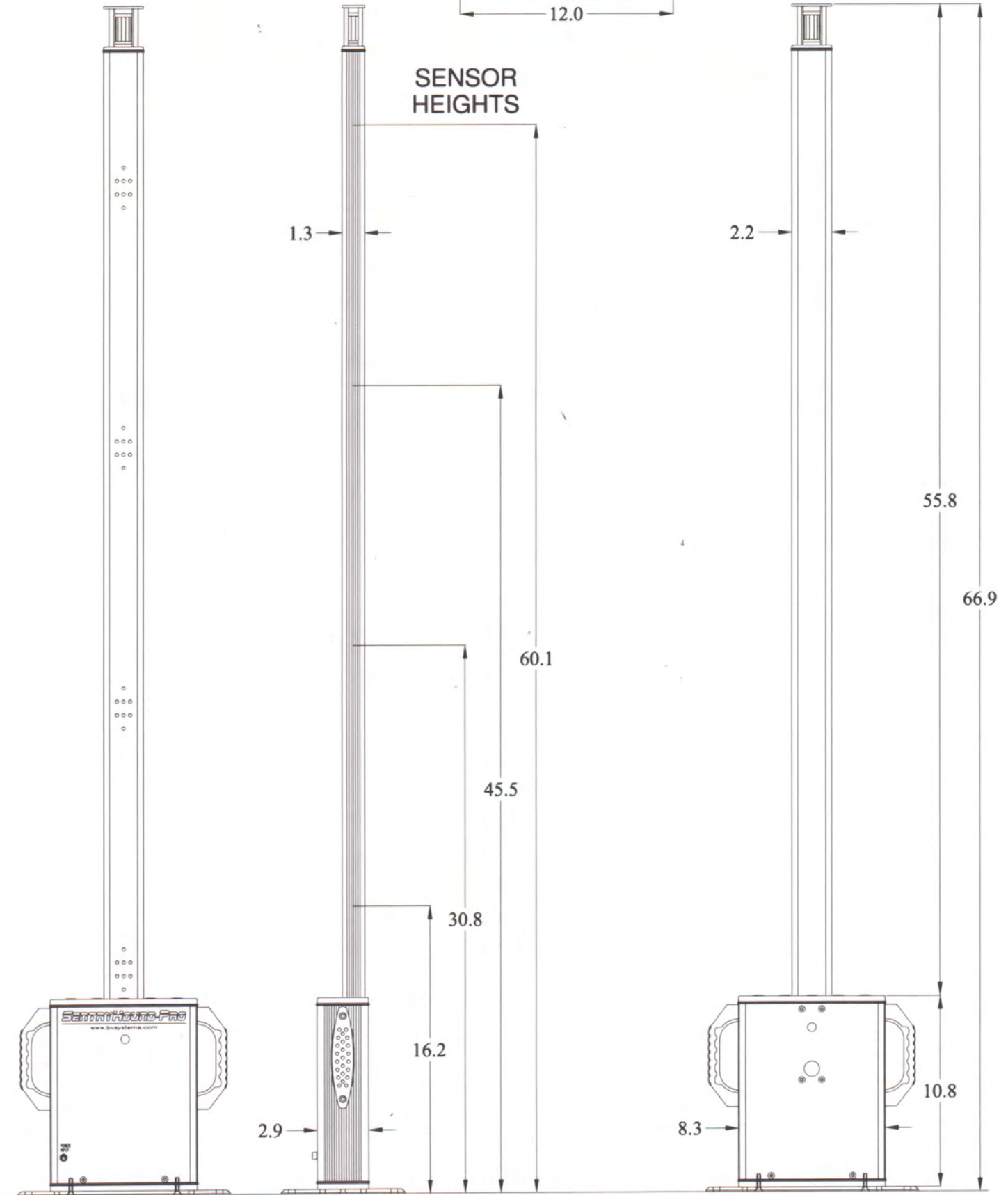
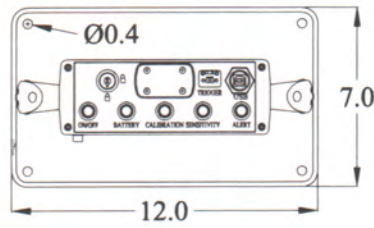

ALL MEASUREMENTS ARE IN INCHES

Thank you for your purchase, we look forward to supporting you and your team.

Customer Support

Berkeley Varitronics Systems, Inc.
Liberty Corporate Park
255 Liberty Street
Metuchen, NJ 08840

8:00 AM to 6:00 PM EST
Toll Free: 888-737-4287
Phone: 732-548-3737
Fax: 732-548-3404

24/7 (expect a reply within one day)
email: support@bvsystems.com
www.bvsystems.com